

REVISIONS

LTR	DESCRIPTION	DATE (YR-MO-DA)	APPROVED
A	Add case outline 2. Delete subgroups 2 and 3 from C and D end points. Editorial changes throughout. Change footnote 4/ on table I.	90-02-02	M. A. Frye
B	Drawing updated to reflect current requirements. Editorial changes throughout. - drw	01-01-25	Raymond Monnin
C	Redraw. Update paragraphs to current boilerplate requirements. - drw	11-10-05	Charles F. Saffle

THE ORIGINAL FIRST SHEET OF THIS DRAWING HAS BEEN REPLACED.

REV																				
SHEET																				
REV																				
SHEET																				

REV STATUS	REV	C	C	C	C	C	C	C	C	C	C	C				
OF SHEETS	SHEET	1	2	3	4	5	6	7	8	9	10					

PMIC N/A	PREPARED BY Joseph A. Kerby	DLA LAND AND MARITIME COLUMBUS, OHIO 43218-3990 http://www.landandmaritime.dla.mil													
STANDARD MICROCIRCUIT DRAWING THIS DRAWING IS AVAILABLE FOR USE BY ALL DEPARTMENTS AND AGENCIES OF THE DEPARTMENT OF DEFENSE AMSC N/A	CHECKED BY Ray Monnin	MICROCIRCUIT, LINEAR, MICROPROCESSOR COMPATIBLE 8-BIT DIGITAL-TO-ANALOG CONVERTER, MONOLITHIC SILICON													
	APPROVED BY Michael A. Frye														
	DRAWING APPROVAL DATE 88-06-30	SIZE A	CAGE CODE 67268	5962-87789											
	REVISION LEVEL C	SHEET		1 OF 10											

1. SCOPE

1.1 Scope. This drawing describes device requirements for MIL-STD-883 compliant, non-JAN class level B microcircuits in accordance with MIL-PRF-38535, appendix A.

1.2 Part or Identifying Number (PIN). The complete PIN is as shown in the following example:

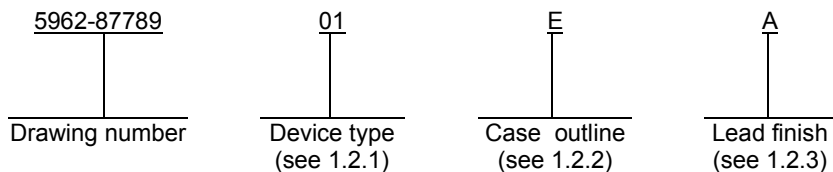

1.2.1 Device types. The device types identify the circuit function as follows:

<u>Device type</u>	<u>Generic number</u>	<u>Circuit function</u>
01	AD558S	8-bit D/A with full microprocessor interface
02	AD558T	8-bit D/A with full microprocessor interface

1.2.2 Case outlines. The case outlines are as designated in MIL-STD-1835 and as follows:

<u>Outline letter</u>	<u>Descriptive designator</u>	<u>Terminals</u>	<u>Package style</u>
E	GDIP1-T16 or CDIP2-T16	16	Dual-in-line
2	CQCC1-N20	20	Square leadless chip carrier

1.2.3 Lead finish. The lead finish is as specified in MIL-PRF-38535, appendix A.

1.3 Absolute maximum ratings.

Positive supply voltage V_{CC} to digital return.....	0 V dc to +18 V dc
Digital input voltage to digital return.....	0 V dc to +7.0 V dc
Output short circuit duration (to ground)	Indefinite
Output short circuit duration (to V_{CC})	Momentary
Power dissipation.....	450 mW
Lead temperature (soldering, 10 seconds)	+300°C
Storage temperature range.....	-65°C to +150°C
Junction temperature (T_J)	+175°C
Thermal resistance, junction-to-case (θ_{JC}).....	See MIL-STD-1835
Thermal resistance, junction-to-ambient (θ_{JA}):	
Case outline E.....	100°C/W
Case outline 2	120°C/W

1.4 Recommended operating conditions.

Positive supply voltage range (V_{CC}):	
2.56 V output range.....	4.5 V dc to 5.5 V dc
10 V output range.....	11.4 V dc to 16.5 V dc
Ambient operating temperature range (T_A).....	-55°C to +125°C

STANDARD MICROCIRCUIT DRAWING DLA LAND AND MARITIME COLUMBUS, OHIO 43218-3990	SIZE A		5962-87789
		REVISION LEVEL C	SHEET 2

2. APPLICABLE DOCUMENTS

2.1 Government specification, standards, and handbooks. The following specification, standards, and handbooks form a part of this drawing to the extent specified herein. Unless otherwise specified, the issues of these documents are those cited in the solicitation or contract.

DEPARTMENT OF DEFENSE SPECIFICATION

MIL-PRF-38535 - Integrated Circuits, Manufacturing, General Specification for.

DEPARTMENT OF DEFENSE STANDARDS

MIL-STD-883 - Test Method Standard Microcircuits.
MIL-STD-1835 - Interface Standard Electronic Component Case Outlines.

DEPARTMENT OF DEFENSE HANDBOOKS

MIL-HDBK-103 - List of Standard Microcircuit Drawings.
MIL-HDBK-780 - Standard Microcircuit Drawings.

(Copies of these documents are available online at <https://assist.daps.dla.mil/quicksearch/> or from the Standardization Document Order Desk, 700 Robbins Avenue, Building 4D, Philadelphia, PA 19111-5094.)

2.2 Order of precedence. In the event of a conflict between the text of this drawing and the references cited herein, the text of this drawing takes precedence. Nothing in this document, however, supersedes applicable laws and regulations unless a specific exemption has been obtained.

3. REQUIREMENTS

3.1 Item requirements. The individual item requirements shall be in accordance with MIL-PRF-38535, appendix A for non-JAN class level B devices and as specified herein. Product built to this drawing that is produced by a Qualified Manufacturer Listing (QML) certified and qualified manufacturer or a manufacturer who has been granted transitional certification to MIL-PRF-38535 may be processed as QML product in accordance with the manufacturers approved program plan and qualifying activity approval in accordance with MIL-PRF-38535. This QML flow as documented in the Quality Management (QM) plan may make modifications to the requirements herein. These modifications shall not affect form, fit, or function of the device. These modifications shall not affect the PIN as described herein. A "Q" or "QML" certification mark in accordance with MIL-PRF-38535 is required to identify when the QML flow option is used.

3.2 Design, construction, and physical dimensions. The design, construction, and physical dimensions shall be as specified in MIL-PRF-38535, appendix A and herein.

3.2.1 Case outlines. The case outlines shall be in accordance with 1.2.2 herein.

3.2.2 Terminal connections. The terminal connections shall be as specified on figure 1.

3.2.3 Truth table. The truth table shall be as specified on figure 2.

3.2.4 Functional block diagram. The functional block diagram shall be as specified on figure 3.

3.2.5 Timing diagram. The timing diagram shall be as specified on figure 4.

3.3 Electrical performance characteristics. Unless otherwise specified herein, the electrical performance characteristics are as specified in table I and shall apply over the full ambient operating temperature range.

3.4 Electrical test requirements. The electrical test requirements shall be the subgroups specified in table II. The electrical tests for each subgroup are described in table I.

STANDARD MICROCIRCUIT DRAWING DLA LAND AND MARITIME COLUMBUS, OHIO 43218-3990	SIZE A		5962-87789
		REVISION LEVEL C	SHEET 3

TABLE I. Electrical performance characteristics.

Test	Symbol	Conditions <u>1/</u> -55°C ≤ T _A ≤ +125°C unless otherwise specified	Group A subgroups	Device type	Limits		Unit
					Min	Max	
Relative accuracy	RA	All bits with positive errors on and all bits with negative errors on	1	All		±0.50	LSB
			2, 3	01		±0.75	
			12	02		±0.25	
			2, 3			±0.375	
Differential nonlinearity	DNL	All major carriers	1, 2, 3	All		±1	LSB
Zero error	V _{ZE}	All bits off	1	All		±1	LSB
			2, 3	01		±2	
			12	02		±0.5	
			2, 3			±1	
Gain error	A _E	No load and 5 mA load, all bits on	1	All		±1.5	LSB
			2, 3	01		±2.5	
			12	02		±0.5	
			2, 3			±1.0	
Output voltage settling time <u>3/</u>	t _{vo} (settling)	0 to 10 V range <u>2/</u>	7	All		3.0	μs
			8			5.0	
		0 to 2.56 V range <u>2/</u>	7	All		1.5	
			8			3.0	
Power supply rejection ratio	PSRR	<u>4/</u>	1, 2, 3	All		0.03	%/%
Power supply current	I _{CC}	All bits on	1, 2, 3	All		±25	mA
Digital input high voltage	V _{IH}		1, 2, 3	All	2.0		V
Digital input low voltage	V _{IL}		1, 2, 3	All		0.8	V
Functional tests <u>3/</u>		See 4.3.1c	7, 8	All			

See footnotes at end of table.

**STANDARD
MICROCIRCUIT DRAWING**
DLA LAND AND MARITIME
COLUMBUS, OHIO 43218-3990

SIZE
A

5962-87789

REVISION LEVEL
C

SHEET
4

TABLE I. Electrical performance characteristics - continued.

Test	Symbol	Conditions ^{1/} -55°C ≤ T _A ≤ +125°C unless otherwise specified	Group A subgroups	Device type	Limits		Unit
					Min	Max	
Digital input high current	I _{IH}	V _{IH} = 7 V	1, 2, 3	All		±100	μA
Digital input low current	I _{IL}	V _{IL} = 0 V	1, 2, 3	All		±100	μA
Write pulse width (strobe)	t _{WR}	^{5/}	9	All	200		ns
			10,11		270		
Data setup time	t _{DS}	^{5/}	9	All	200		ns
			10,11		270		
Data hold time	t _{DH}	^{5/}	9, 10, 11	All	10		ns

- ^{1/} V_{CC} = +5 V for 0 to 2.56 V range, V_{CC} = +15 V for 0 to 10 V range (unless otherwise specified).
- ^{2/} Settling time is specified for a positive full scale step to ±1/2 LSB.
- ^{3/} Guaranteed if not tested.
- ^{4/} V_{CC} = 4.5 V to 5.5 V for 0 to 2.56 V range, V_{CC} = 11.4 V to 16.5 V for 0 to 10 V range.
- ^{5/} Timing per figure 4.

3.5 Marking. Marking shall be in accordance with MIL-PRF-38535, appendix A. The part shall be marked with the PIN listed in 1.2 herein. In addition, the manufacturer's PIN may also be marked. For packages where marking of the entire SMD PIN number is not feasible due to space limitations, the manufacturer has the option of not marking the "5962-" on the device.

3.5.1 Certification/compliance mark. A compliance indicator "C" shall be marked on all non-JAN devices built in compliance to MIL-PRF-38535, appendix A. The compliance indicator "C" shall be replaced with a "Q" or "QML" certification mark in accordance with MIL-PRF-38535 to identify when the QML flow option is used.

3.6 Certificate of compliance. A certificate of compliance shall be required from a manufacturer in order to be listed as an approved source of supply in MIL-HDBK-103 (see 6.6 herein). The certificate of compliance submitted to DLA Land and Maritime -VA prior to listing as an approved source of supply shall affirm that the manufacturer's product meets the requirements of MIL-PRF-38535, appendix A and the requirements herein.

3.7 Certificate of conformance. A certificate of conformance as required in MIL-PRF-38535, appendix A shall be provided with each lot of microcircuits delivered to this drawing.

3.8 Notification of change. Notification of change to DLA Land and Maritime -VA shall be required for any change that affects this drawing.

3.9 Verification and review. DLA Land and Maritime, DLA Land and Maritime's agent, and the acquiring activity retain the option to review the manufacturer's facility and applicable required documentation. Offshore documentation shall be made available onshore at the option of the reviewer.

STANDARD MICROCIRCUIT DRAWING DLA LAND AND MARITIME COLUMBUS, OHIO 43218-3990	SIZE A		5962-87789
		REVISION LEVEL C	SHEET 5

Device type	01 and 02	
Case outline	E	2
Terminal number	Terminal symbol	
1	DB0 (LSB)	NC
2	DB1	DB0 (LSB)
3	DB2	DB1
4	DB3	DB2
5	DB4	DB3
6	DB5	NC
7	DB6	DB4
8	DB7 (MSB)	DB5
9	$\overline{\text{CE}}$	DB6
10	$\overline{\text{CS}}$	DB7 (MSB)
11	+V _{CC}	NC
12	GND	$\overline{\text{CE}}$
13	GND	$\overline{\text{CS}}$
14	V _{OUT} select	+V _{CC}
15	V _{OUT} sense	GND
16	V _{OUT}	NC
17	---	GND
18	---	V _{OUT} select
19	---	V _{OUT} sense
20	---	V _{OUT}

NC = no connection

FIGURE 1. Terminal connections.

STANDARD MICROCIRCUIT DRAWING DLA LAND AND MARITIME COLUMBUS, OHIO 43218-3990	SIZE A		5962-87789
		REVISION LEVEL C	SHEET 6

Input data	$\overline{\text{CE}}$	$\overline{\text{CS}}$	DAC data	Latch condition
0	0	0	0	"Transparent"
1	0	0	1	"Transparent"
0	↑	0	0	Latching
1	↑	0	1	Latching
0	0	↑	0	Latching
1	0	↑	1	Latching
X	1	X	Previous data	Latched
X	X	1	Previous data	Latched

X = Does not matter.

↑ = Logic threshold at positive-going transition.

FIGURE 2. Truth table.

**STANDARD
MICROCIRCUIT DRAWING**
DLA LAND AND MARITIME
COLUMBUS, OHIO 43218-3990

SIZE
A

5962-87789

REVISION LEVEL
C

SHEET
7

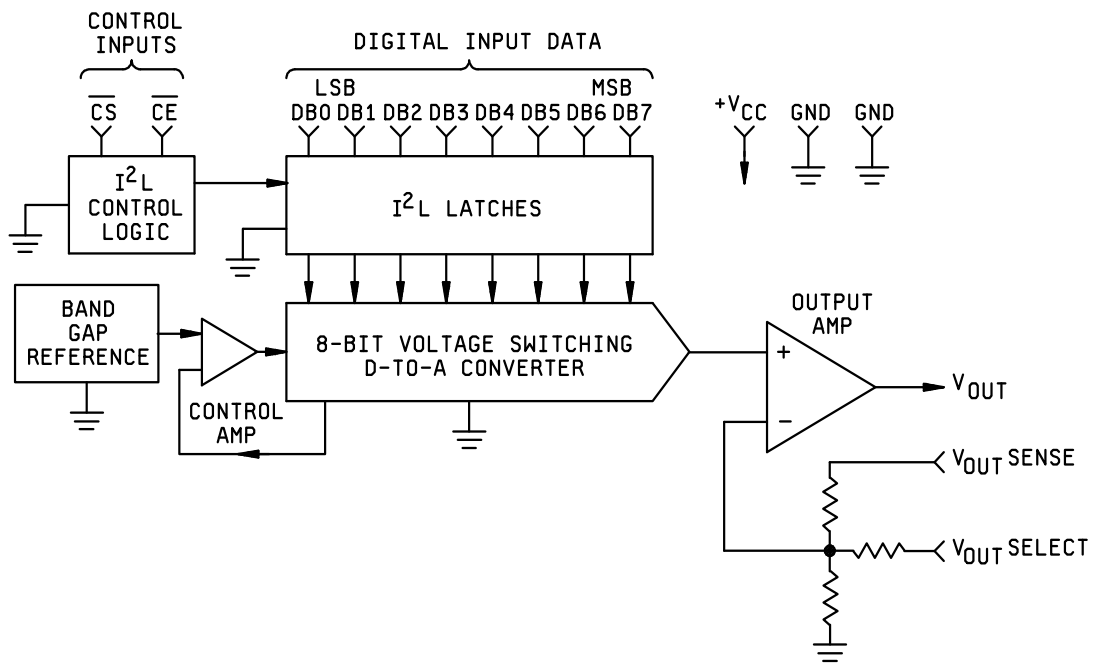

FIGURE 3. Functional block diagram.

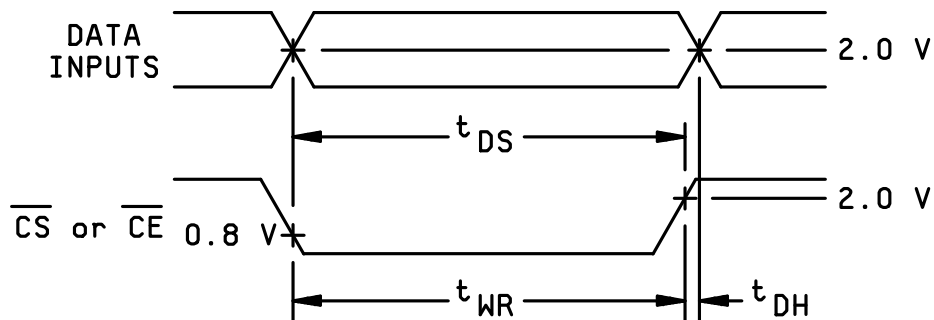

FIGURE 4. Timing diagram.

**STANDARD
MICROCIRCUIT DRAWING**
DLA LAND AND MARITIME
COLUMBUS, OHIO 43218-3990

SIZE
A

5962-87789

REVISION LEVEL
C

SHEET
8

4. VERIFICATION

4.1 Sampling and inspection. Sampling and inspection procedures shall be in accordance with MIL-PRF-38535, appendix A.

4.2 Screening. Screening shall be in accordance with method 5004 of MIL-STD-883, and shall be conducted on all devices prior to quality conformance inspection. The following additional criteria shall apply:

- a. Burn-in test, method 1015 of MIL-STD-883.
 - (1) Test condition A, B, C, or D. The test circuit shall be maintained by the manufacturer under document revision level control and shall be made available to the preparing or acquiring activity upon request. The test circuit shall specify the inputs, outputs, biases, and power dissipation, as applicable, in accordance with the intent specified in method 1015 of MIL-STD-883.
 - (2) $T_A = +125^{\circ}\text{C}$, minimum.
- b. Interim and final electrical test parameters shall be as specified in table II herein, except interim electrical parameter tests prior to burn-in are optional at the discretion of the manufacturer.
- c. Optional subgroup 12 is used for grading and part selection at $+25^{\circ}\text{C}$, it is not included in PDA.

TABLE II. Electrical test requirements.

MIL-STD-883 test requirements	Subgroups (in accordance with MIL-STD-883, method 5005, table I)
Interim electrical parameters (method 5004)	1
Final electrical test parameters (method 5004)	1*, 2, 3, 9, 12
Group A test requirements (method 5005)	1, 2, 3, 7**, 8**, 9, 10, 11, 12
Groups C and D end-point electrical parameters (method 5005)	1

* PDA applies to subgroup 1.

** Subgroups 7 and 8 are guaranteed, if not tested, to the limits specified in table I.

4.3 Quality conformance inspection. Quality conformance inspection shall be in accordance with method 5005 of MIL-STD-883 including groups A, B, C, and D inspections. The following additional criteria shall apply.

4.3.1 Group A inspection.

- a. Tests shall be as specified in table II herein.
- b. Subgroups 4, 5, and 6 in table I, method 5005 of MIL-STD-883 shall be omitted.
- c. Subgroups 7 and 8 shall include verification of the truth table.
- d. Optional subgroup 12 is used for grading and part selection at $+25^{\circ}\text{C}$.

STANDARD MICROCIRCUIT DRAWING DLA LAND AND MARITIME COLUMBUS, OHIO 43218-3990	SIZE A		5962-87789
		REVISION LEVEL C	SHEET 9

4.3.2 Groups C and D inspections.

- a. End-point electrical parameters shall be as specified in table II herein.
- b. Steady-state life test conditions, method 1005 of MIL-STD-883.
 - (1) Test condition A, B, C, or D. The test circuit shall be maintained by the manufacturer under document revision level control and shall be made available to the preparing or acquiring activity upon request. The test circuit shall specify the inputs, outputs, biases, and power dissipation, as applicable, in accordance with the intent specified in method 1005 of MIL-STD-883.
 - (2) $T_A = +125^{\circ}\text{C}$, minimum.
 - (3) Test duration: 1,000 hours, except as permitted by method 1005 of MIL-STD-883.

5. PACKAGING

5.1 Packaging requirements. The requirements for packaging shall be in accordance with MIL-PRF-38535, appendix A.

6. NOTES

6.1 Intended use. Microcircuits conforming to this drawing are intended for use for Government microcircuit applications (original equipment), design applications, and logistics purposes.

6.2 Replaceability. Microcircuits covered by this drawing will replace the same generic device covered by a contractor-prepared specification or drawing.

6.3 Configuration control of SMD's. All proposed changes to existing SMD's will be coordinated with the users of record for the individual documents. This coordination will be accomplished using DD Form 1692, Engineering Change Proposal.

6.4 Record of users. Military and industrial users shall inform DLA Land and Maritime when a system application requires configuration control and the applicable SMD to that system. DLA Land and Maritime will maintain a record of users and this list will be used for coordination and distribution of changes to the drawings. Users of drawings covering microelectronics devices (FSC 5962) should contact DLA Land and Maritime -VA, telephone (614) 692-0544.

6.5 Comments. Comments on this drawing should be directed to DLA Land and Maritime -VA, Columbus, Ohio 43218-3990, or telephone (614) 692-0540.

6.6 Approved sources of supply. Approved sources of supply are listed in MIL-HDBK-103. The vendors listed in MIL-HDBK-103 have agreed to this drawing and a certificate of compliance (see 3.6 herein) has been submitted to and accepted by DLA Land and Maritime -VA.

STANDARD MICROCIRCUIT DRAWING DLA LAND AND MARITIME COLUMBUS, OHIO 43218-3990	SIZE A		5962-87789
		REVISION LEVEL C	SHEET 10

STANDARD MICROCIRCUIT DRAWING BULLETIN

DATE: 11-10-05

Approved sources of supply for SMD 5962-87789 are listed below for immediate acquisition information only and shall be added to MIL-HDBK-103 and QML-38535 during the next revision. MIL-HDBK-103 and QML-38535 will be revised to include the addition or deletion of sources. The vendors listed below have agreed to this drawing and a certificate of compliance has been submitted to and accepted by DLA Land and Maritime -VA. This information bulletin is superseded by the next dated revision of MIL-HDBK-103 and QML-38535. DLA Land and Maritime maintains an online database of all current sources of supply at <http://www.landandmaritime.dla.mil/Programs/Smcr/>.

Standard microcircuit drawing PIN <u>1/</u>	Vendor CAGE number	Vendor similar PIN <u>2/</u>	Reference military specification part number
5962-87789012A	24355	AD558SE/883B	
5962-8778901EA	24355	AD558SD/883B	
5962-87789022A	24355	AD558TE/883B	
5962-8778902EA	24355	AD558TD/883B	M38510/14401BEA

1/ The lead finish shown for each PIN representing a hermetic package is the most readily available from the manufacturer listed for that part. If the desired lead finish is not listed contact the vendor to determine its availability.

2/ Caution. Do not use this number for item acquisition. Items acquired to this number may not satisfy the performance requirements of this drawing.

Vendor CAGE number

24355

Vendor name and address

Analog Devices
 Rt 1 Industrial Park
 PO Box 9106
 Norwood, MA 02062
 Point of contact: 804 Woburn Street
 Wilmington, MA 01887-3462

The information contained herein is disseminated for convenience only and the Government assumes no liability whatsoever for any inaccuracies in the information bulletin.